

TOHO ELECTRONICS INC.

Operation Manual (Communication Edition)
(TOHO Protocol, MODBUS)

Model: TTM-000W Series
Name: Digital Controller

Thank you very much for purchasing the TTM-000W Series (with a communication function).
Kindly read this operation manual for proper usage.

Table of Contents

1.	Before Using the Product	Page 4
	1.1 About the Operation Manual	
	1.2 Requirements for Communication	
	1.3 Things the Communication Function Can Do	
	1.4 Position (Priority) of Communication	
	1.5 Settings to Be Made Prior to the Communication	
2.	Setting about TOHO Communication.	Page 5
	2.1 Outline	
	2.2 Setting of Data Length	
	2.3 Setting of Stop Bit	
	2.4 Setting of Parity	
	2.5 Setting of BCC Checking	
	2.6 Setting of Communication Speed	
	2.7 Setting of Communication Address	
	2.8 Setting of Response Delay Time	
	2.9 Switching of Communication Mode	
3.	TOHO Communication Control.	Page 8
	3.1 Communication Procedures	
	3.2 Kinds of Message	
	3.3 Structure of Request Message (Data transmission from upper computer to this product)	
	3.4 Structure of Response Message (Data transmission from this product to upper computer)	
	3.5 Explanation about Codes (e.g., List of Errors)	
	3.6 Things to Be Noted during the Communication	
4.	Sample TOHO Communication.	Page 14
	4.1 Sample Communication for Reading	
	4.2 Sample Communication for Writing	
5.	Setting about MODBUS Communication.	Page 16
	5.1 Outline	
	5.2 Setting of Data Length	
	5.3 Setting of Stop Bit	
	5.4 Setting of Parity	
	5.5 Setting of BCC Checking	
	5.6 Setting of Communication Speed	
	5.7 Setting of Communication Address	
	5.8 Setting of Response Delay Time	
	5.9 Switching of Communication Mode	

6.	MODBUS Communication Control.	Page 19
	6.1 Communication Procedures	
	6.2 Kinds of Message	
	6.3 Structure of RTU Request Message (Data transmission from upper computer to this product)	
	6.4 Structure of RTU Response Message (Data transmission from this product to upper computer)	
	6.5 Explanation about RTU Codes (e.g., List of Errors)	
	6.6 Things to Be Noted during RTU Communication	
	6.7 Sample Computation of CRC-16	
	6.8 Structure of ASCII Request Message (Data transmission from upper computer to this product)	
	6.9 Structure of ASCII Response Message (Data transmission from this product to upper computer)	
	6.10 Explanation about ASCII Codes (e.g., List of Errors)	
	6.11 Things to Be Noted during ASCII Communication	
	6.12 Sample Computation of LRC	
7.	Specifications	Page 32
	7.1 Type of Communication Standard	
	7.2 Communication Specifications	
8.	Wiring	Page 33
9.	List of Identifiers (Codes)	Page 34
10.	List of ASCII Codes	Page 38

1. Before Using the Product

1.1 About the Operation Manual

This manual explains the communication function of TTM-000W (hereinafter referred to as "Product").

1.2 Requirements for Communication

The communication function of the product is optional. Therefore, you need to specify the communication option (RS-485) upon purchase.

1.3 Things the Communication Function Can Do

This function allows the user to write and read the items of this product that are described in "9. List of Identifiers,"

such as "To change, start, or stop items that can be operated through front keys" and "To read the information that can be displayed on the display section."

However, since the RAM of this product is used during the reading/writing of data through ordinary command, data that was written will be replaced by the previous data (data that is saved in the EEPROM) if the power is turned OFF and then turned ON.

To save the written data into the EEPROM of this product, execute the save request message.

(See 3.6, 6.6, and 6.11, "Things to Be Noted during the Communication.")

Furthermore, unnecessary setting items, such as items that are related to the unattached option, will not be read and written.

1.4 Position (Priority) of Communication

This product allows the user to change data and parameters through the key even during the operation under communication mode.

Change of settings of data and parameters via communication will be disabled while the product is operated under RO (Read Only) (provided, however, that the switching of communication mode is possible).

1.5 Settings to Be Made Prior to the Communication

Several settings need to be made to this product in order for it to perform a communication function.

See "2. Setting about TOHO Communication" or "5. Setting about MODBUS Communication."

2. Setting about TOHO Communication

2.1 Outline

Initial settings need to be made to the product in order for it to perform a communication function. The setting shall be done by keys at the front side.

Follow the procedure shown below to navigate between setting screens. See the User's Manual of this product for details.

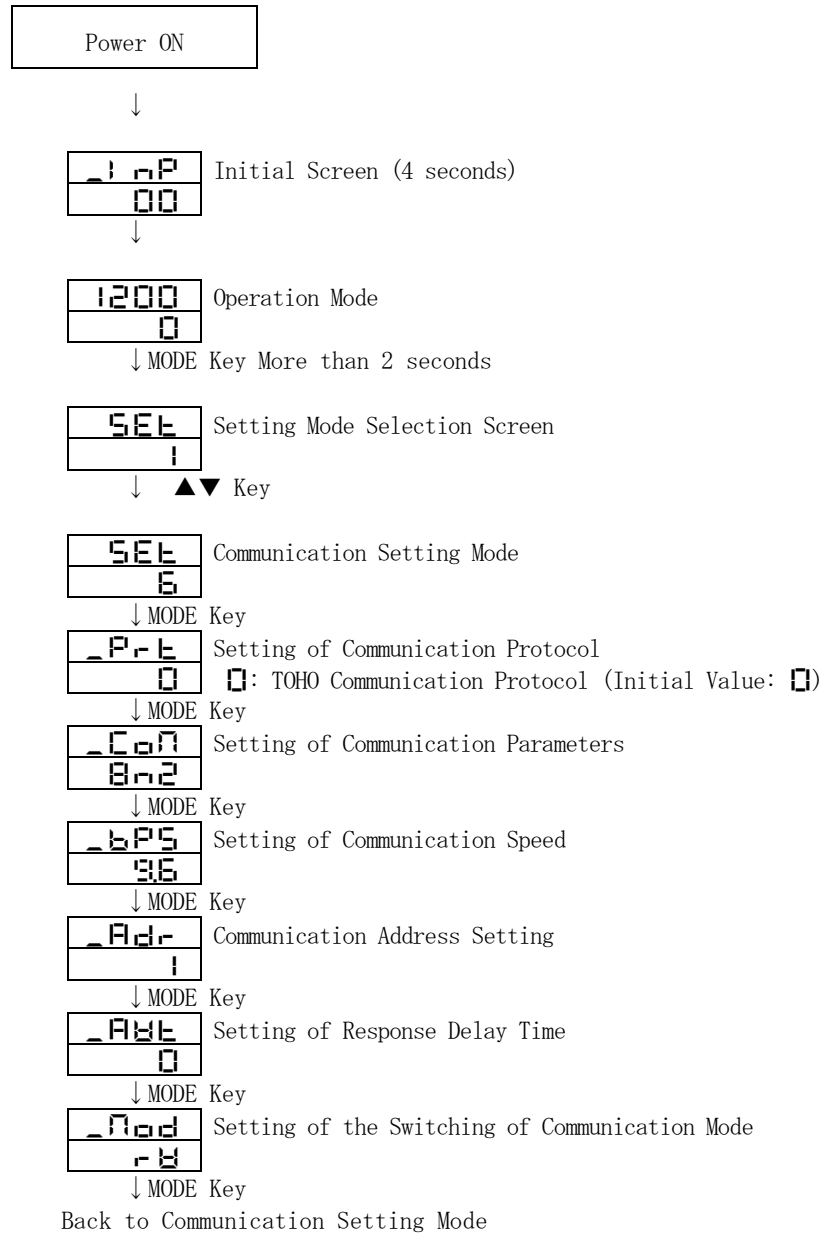

When the setting is done, press the MODE key for more than 2 seconds to return to the operation mode. Each parameter shown above is the initial value.

- 2.2 Setting of Data Length
- 2.3 Setting of Stop Bit
- 2.4 Setting of Parity
- 2.5 Setting of BCC Checking

Set the value by pressing the ▲▼ keys on the "Setting of Communication Parameters" screen in a previous page. The initial value is **68n2**.

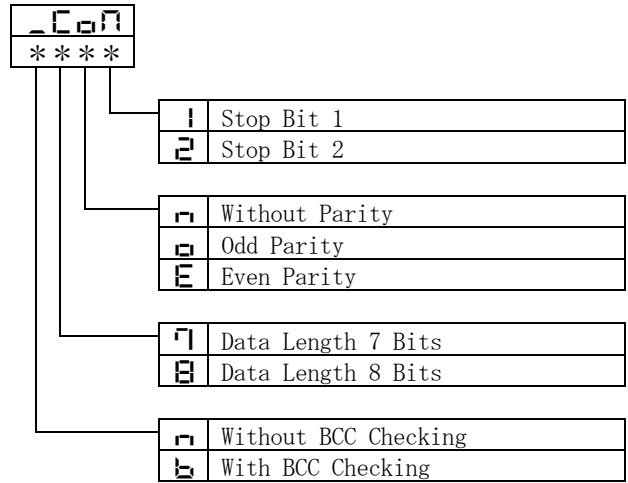

2.6 Setting of Communication Speed

Set the value by pressing the ▲▼ keys on the "Setting of Communication Speed" screen in a previous page. The initial value is **96**.

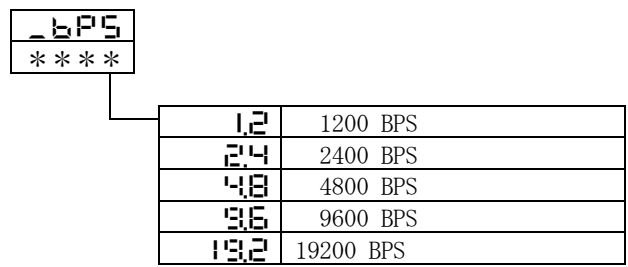

2.7 Setting of Communication Address

Set the value by pressing the ▲▼ keys on the "Setting of Communication Address" screen in a previous page. The initial value is **1**.



2.8 Setting of Response Delay Time

Set the time to take for the upper computer to complete the receiving of "request message," open the line, and get ready for the next input.

Set the value by pressing the ▲▼ keys on the "Setting of Response Delay Time" screen in a previous page. The initial value is **0**.

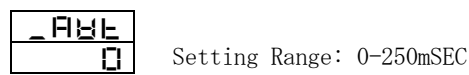

- *Communication may not be performed properly if the response delay time is too short.
- *In actual operation, the processing time of the product will be added to the response delay time.

2.9 Switching of Communication Mode

Set the value by pressing the ▲▼ keys on the "Setting of the Switching of Communication Mode" screen in a previous page. The initial value is **r b**.

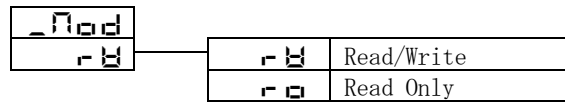

3. TOHO Communication Control

3.1 Communication Procedures

This product returns the "response message" as a reply to the "request message" that will be sent by the upper computer.

Therefore, the transmission will never be initiated by this product.

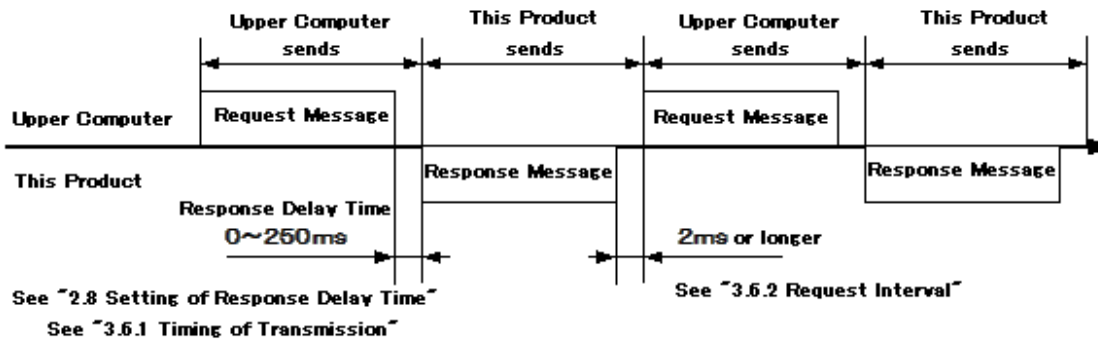

3.2 Kinds of Message

■ Kinds of message can be briefly classified into the following:

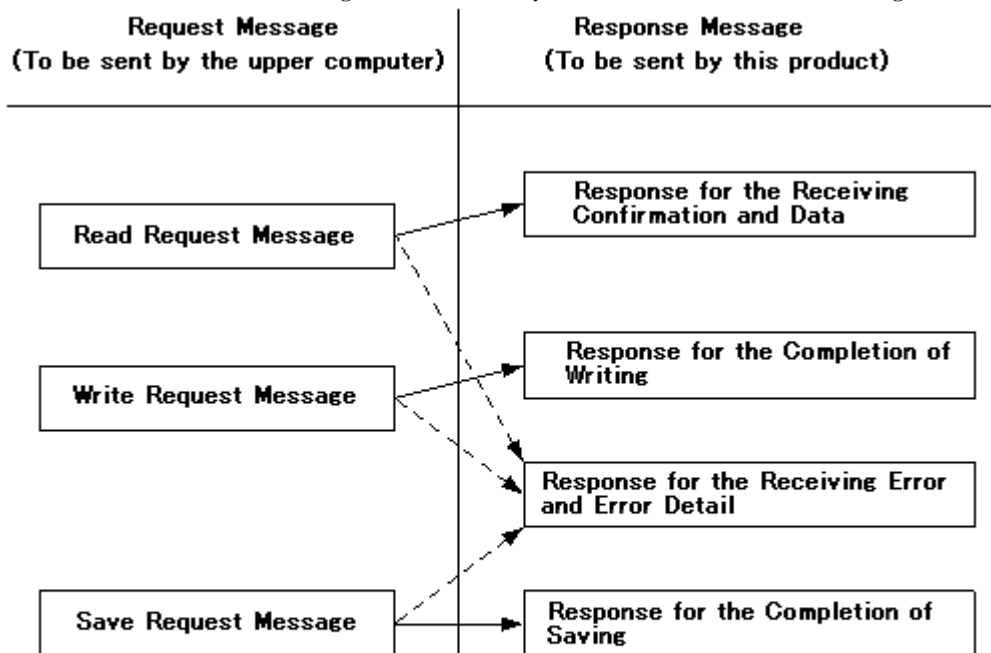

————▶ : Response for the case when the normal "Request Message" was received
 - - - - -▶ : If the "Request Message" contains error

- All codes up to ETX, such as STX and data (except for BCC), will be expressed in ASCII code.
- To code the program for the upper computer, see "9. List of Identifiers" and "10. List of ASCII Codes" at the end of this document.

3.3 Structure of Request Message (Data transmission from upper computer to this product)

- See "3.5 Explanation about Codes" for codes from ① to ⑩.
- See "4.1 Sample Communication for Reading" and "4.2 Sample Communication for Writing" for concrete samples of the request message.

3.3.1 Structure of Read Request Message



3.3.2 Structure of Write Request Message

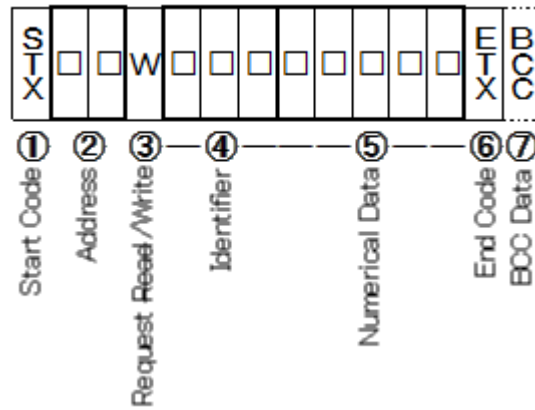

3.3.3 Structure of Save Request Message

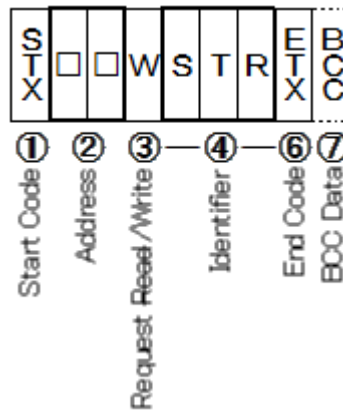

3.4 Structure of Response Message (Data transmission from this product to upper computer)

- See "3.5 Explanation about Codes" for codes from ① to ⑩.
- See "4.1 Sample Communication for Reading" and "4.2 Sample Communication for Writing" for concrete samples of the request message.

3.4.1 Response Message for Read Request Message

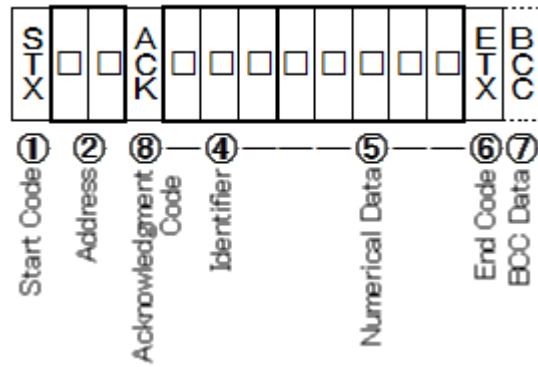

3.4.2 Response Message for Write/Save Request Message

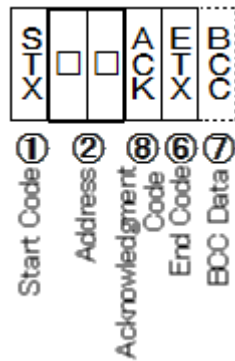

3.4.3 Response Message for the Error

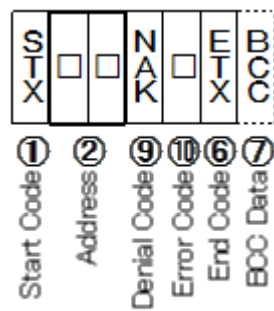

3.5 Explanation about Codes

- The following codes from ① STX, ② Address, up to ⑩ Error Type will be expressed in ASCII code:
- See "10. List of ASCII Codes" for the details about ASCII codes.
- To convert into ASCII code, see "4. Sample TOHO Communications."

① STX

It is a code that is necessary for the receiving side to detect the start of the message.
It shall be attached to the start of the character string to be sent.

② Address

It is an address of the device that will be communicated by the upper computer (this product).
The address in the response message from this product indicates the source of the response message.

③ Contents of Request

Set the symbol R, W, L, or B.

R: If the data is to be read from the product

W: If the data is to be written or saved into the product

L: If the blind setting is to be read from the product

B: If the blind setting is to be written into the product

④ Identifier

It is a classification symbol (identifier) of the data to be read or written that will be expressed by the 3-digit alphanumeric characters.
See "9. List of Identifiers (Codes)."

⑤ Numerical Data

It is a data for reading or writing which will be expressed in 5-digit characters regardless of the data type.

Negative data: The symbol "-" is considered one digit to be displayed at the largest digit.
Position of decimal point: Decimal point will not be included in the 5-digit data.

Example: 5-digit numerical data "-1999" means the following:

	Settings	Meaning of Numerical Value
Data of which the position of decimal point can be changed (PV/SV), etc.	If the position of decimal point [_ dP] is 0	-1999
	If the position of decimal point [_ dP] is 0.0	-199. 9
	If the position of decimal point [_ dP] is 0.00	-19. 99
	If the position of decimal point [_ dP] is 0.000	-1. 999

- ⑥ ETX
It is a code that is necessary for the receiving side to detect the end of the message.
It shall be attached to the end of the character string to be sent (except for BCC).
- ⑦ BCC
Get the Ex-OR of all characters from STX to ETX with the check code for the detection of error.
This code shall not be included in the response message if BCC Check is turned OFF at the communication setting of this product. See "2. Setting about TOHO Communication."
- ⑧ ACK
It is an acknowledge code that will be included in the "response message" to be replied by this product if no error is found in the received message.
- ⑨ NAK
It is a reject code that will be included in the "response message" to be replied by this product if error is found in the received message.
If there is an error in the received "request message," content of error (⑩ Type of ERR) will also be attached (next to NAK) to the "response message" that will be returned by this product.
- ⑩ Type of ERR
If there is an error in the "request message" that was received by this product, the description of the said error (number in the table shown below) will be attached (next to "⑨ NAK") to the "response message" that will be returned by this product.
Since error number "0" indicates the breakdown of measuring equipment (memory error or A/D conversion error), it will be included in the "response message" whether or not there is an error in the "request message."
Since error number "9" indicates AT error, it will be included in the "response message" whether or not there is an error in the "request message." Remove the cause of the error immediately and restart the AT.
For multiple errors, the largest error number will be included.

Contents and classification of error are the following:

Error Number	Description of errors in the "request message" that was received by this product
0	Malfunction of measuring equipment (memory error or A/D conversion error)
1	Numerical value data is out of the "setting range that is specified individually by the setting item"
2	Changing of the requested item is prohibited or no item to read
3	ASCII code that is other than the numeric value has been set to the portion for the numeric value. ASCII code that is other than "0" or "-" has been set to the position for the symbol.
4	Format Error
5	BCC Error
6	Overflow Error
7	Framing Error
8	Parity Error
9	PV abnormality has occurred during AT or AT does not end although 3 hours have lapsed

3.6 Things to Be Noted during the Communication

3.6.1 Timing of Transmission

Upon using RS-485, set enough response delay time to ensure the communication (sending/receiving) with the host computer.

See Figure of "3.1 Communication Procedures" and "2.8 Setting of Response Delay Time."

3.6.2 Request Interval

If the "request message" is to be sent continuously by the upper computer, wait for at least 2msecs. from the arrival of the "response message" from this product before sending the next request message.

3.6.3 Conditions for Response

This product will not return the "response message" if STX and ETX (BCC) are not included in the "request message."

Therefore, although there is an error in the "request message," the "response message" with NAK And ERR will not be returned unless the above condition is met.

Therefore, the upper computer should resend the necessary "request message" if the "response message" is not returned within the reasonable time.

Once STX is received, this product clears all codes that were received prior to the said STX.

3.6.4 Address Specification Error

This product will not respond to any "request message" that specifies the address that is other than the one that has been set to itself.

Therefore, if there is an error in the address section of the "request message," none of the slave stations will return the "response message."

Therefore, the upper computer should resend the necessary "request message" if the "response message" is not returned within the reasonable time.

Once STX is received, this product clears all codes that were received prior to the said STX.

3.6.5 Number of Digits of Data and Position of Decimal Point

See "3.5 Explanation about Codes ⑤ Numerical Data."

3.6.6 Operation After the Receiving of Save Request Message

This product starts the saving of data once it receives the save request message correctly from the upper computer.

Only the data that is different from the one stored in the EEPROM (changed data) shall be saved.

Time that is required to save the data (TW) is within 6 seconds.

The product sends a response (ACK) when the saving of data is completed.

Some data may be lost if the product is turned OFF while the saving process is in progress. Do not turn the power of this product OFF for at least 6 seconds after the sending of the save request message.

3.6.7 Upon Turning the Power ON

This product will not perform any communication for approximately 4 seconds after turning its power ON (no response). Set the delay from power ON to start communication.

3.6.8 Saving the Data Other than Save Request Message

This product saves the parameter into the EEPROM even without receiving the save request message In case of the following:

- 1) If the parameter is changed through key operation, it writes only changed parameters and other related parameters.
- 2) If the auto tuning is activated and ended normally, only the PID constant will be written.

3.6.9 Change of Setting Value (SV or SV2) by the Communication during Auto Tuning

If the value for control (SV or SV2) is changed via communication while the auto tuning is performed, the said value (SV or SV2) will not be changed until auto tuning ends.

4. Example of TOHO Communication

4.1 Sample Communication for Reading

Example:

Request Message: Request this product, which address is set as "27," to read the measured value (PV).

(Upper computer)

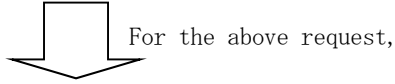

Response Message: Returns the data (00777) of the measured value (PV).
(This product)

Read Request Message (to be sent by the upper computer)

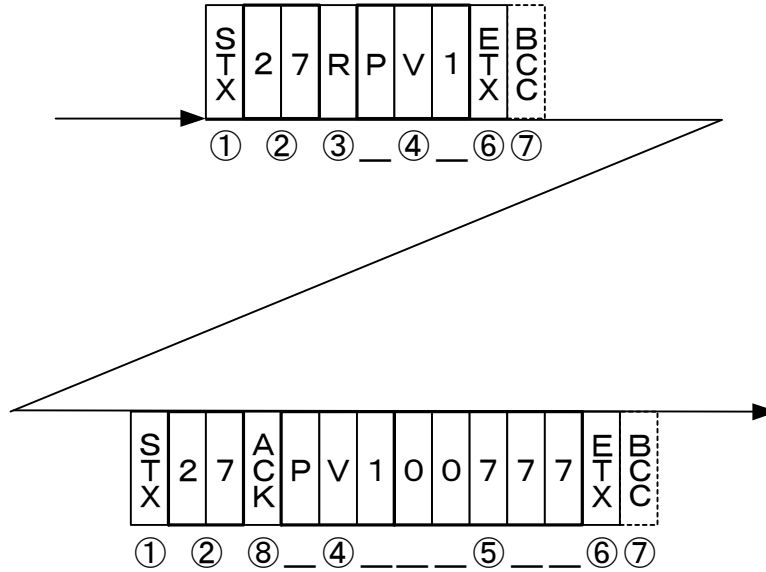

Code	Symbol · Data	ASCII Code Note 2)
① Start Code	STX	02H
② Address	27	32H 37H
③ Contents of Request	R (Read)	52H
④ Identifier Note 1	PV1	50H 56H 31H
⑤ Numerical Data	00777	30H 30H 37H 37H 37H
⑥ End Code	ETX	03H
⑦ BCC Data Request		61H
Re-		02H
⑧ Acknowledgment Code	ACK	06H

Note 1: See "9. List of Identifiers (Codes)."

Note 2: See "10. List of ASCII Codes" for the details about ASCII codes.

4.2 Sample Communication for Writing

Example:

Request Message: Request this product, which address is set as "03," to "set 011" (write 011) to EIF (upper computer).

(Set the function of Event 1 to Minimum Deviation + Retain)

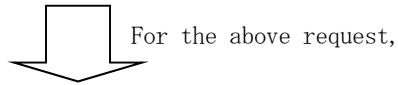

Response Message: Return the message to tell that the request message has been received. (This product)

☆ Read the data separately to check if the data is written correctly.

Write Request Message (to be sent by the upper computer)

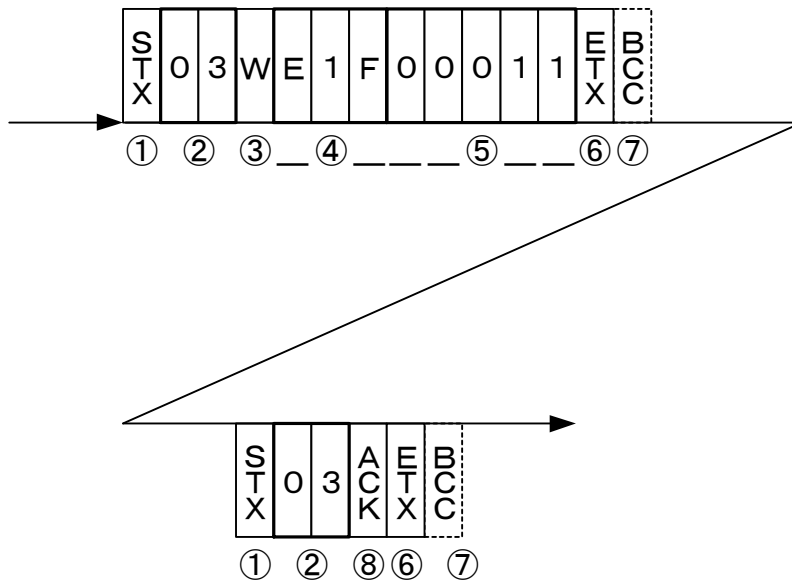

Code	Symbol · Data	ASCII Code Note 2)
① Start Code	STX	02H
② Address	03	30H 33H
③ Contents of Request	W (Write)	57H
④ Identifier Note 1	EIF	45H 31H 46H
⑤ Numerical Data	00011	30H 30H 30H 31H 31H
⑥ End Code	ETX	03H
⑦ BCC Data Request		57H
Re-		04H
⑧ Acknowledgment Code	ACK	06H

Note 1: See "9. List of Identifiers (Codes)."

Note 2: See "10. List of ASCII Codes" for the details about ASCII codes.

5. Setting about MODBUS Communication

5.1 Outline

Initial settings need to be made to the product in order for it to perform a communication function. The setting shall be done by keys at the front side. Follow the procedure shown below to navigate between setting screens. See the User's Manual of the product for details.

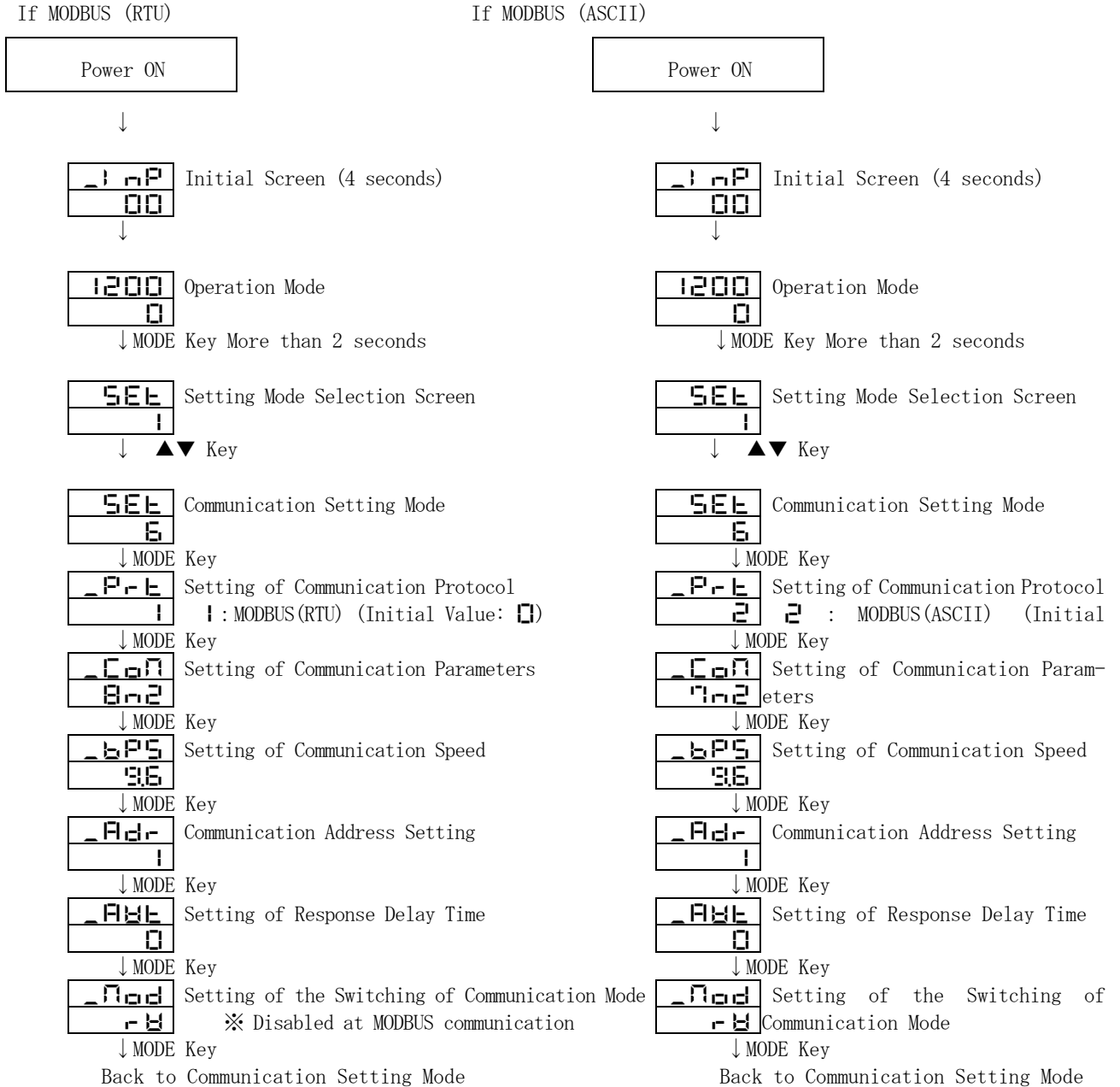

When the setting is done, press the MODE key for more than 2 seconds to return to the operation mode.

5.2 Setting of Data Length

5.3 Setting of Stop Bit

5.4 Setting of Parity

5.5 Setting of BCC Checking

BCC checking will be disabled.

Initial Value of MODBUS (RTU): **8n2** Initial Value of MODBUS (ASCII): **7n2**

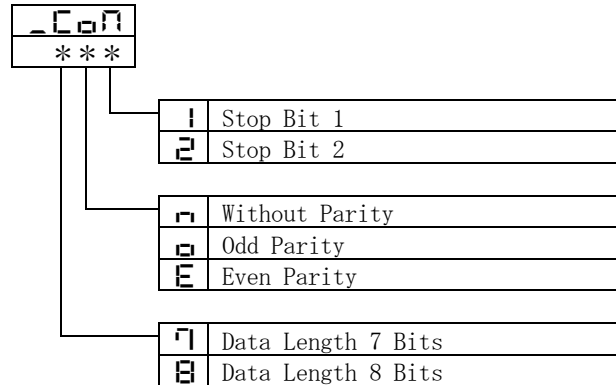

※ The setting of RTU is only three types, namely, **8n2**, **8o1**, and **8E1**.

The setting of ASCII is only three types, namely, **7n2**, **7o1**, and **7E1**.

5.6 Setting of Communication Speed

Set the value by pressing the ▲▼ keys on the "Setting of Communication Speed" screen in a previous page. The initial value is **96**.

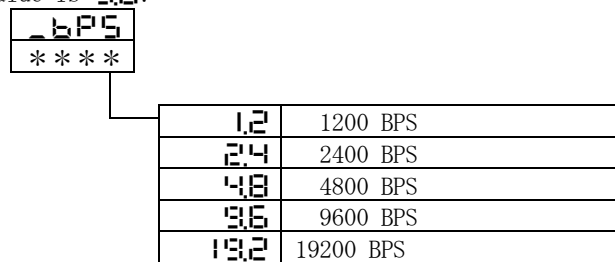

5.7 Setting of Address

Set the value by pressing the ▲▼ keys on the "Setting of Communication Address" screen in a previous page. The initial value is **1**.



5.8 Setting of Response Delay Time

Set the time to take for the upper computer to complete the receiving of "request message," open the line, and get ready for the next input. Set the value by pressing the ▲▼ keys on the "Setting of Response Delay Time" screen in a previous page. The initial value is **0**.

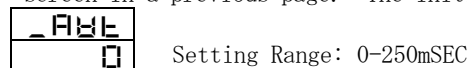

*Communication may not be performed properly if the response delay time is too short.

*In actual operation, the processing time of the product will be added to the response delay time.

5.9 Switching of Communication Mode

Switching of communication mode is disabled in MODBUS communication. (Read/Write is allowed at all times.) The setting can be changed by operating the ▲▼ keys on the "Setting of the Switching of Communication Mode" screen in a previous page. The initial value is **rW**.

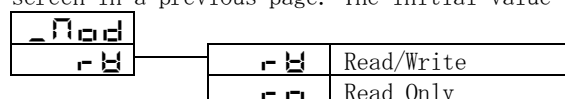

6. MODBUS Communication Control

6.1 Communication Procedures

This product returns the "response message" as a reply to the "request message" that will be sent by the upper computer.
Therefore, the transmission will never be initiated by this product.

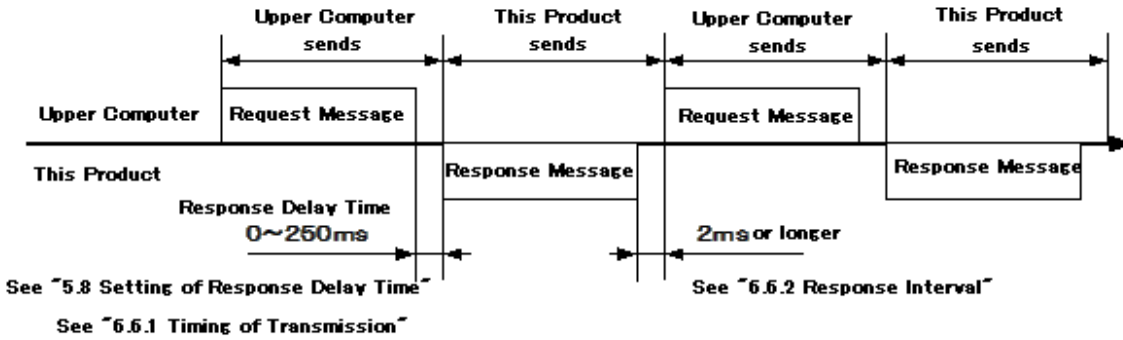

6.2 Kinds of Message

■ Kinds of message can be briefly classified into the following:

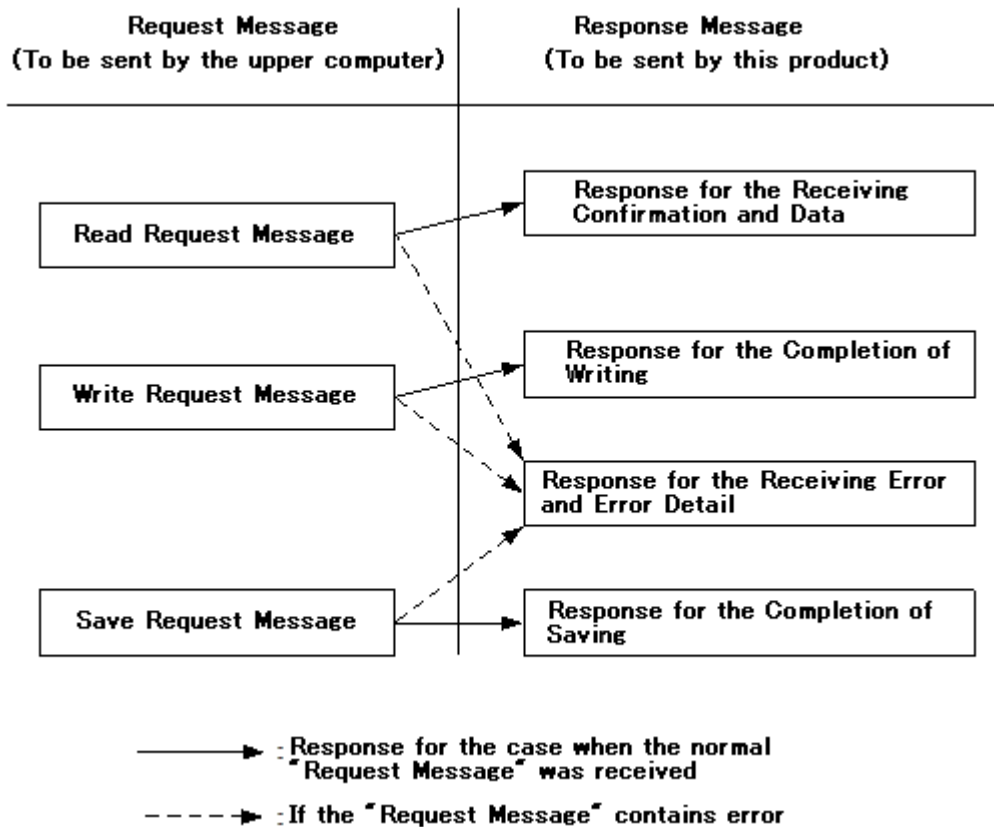

- Data is in binary during RTU mode.
- In case of ASCII mode, all codes will be expressed in ASCII code.
- To code the program for the upper computer, see "9. List of Identifiers" and "10. List of ASCII Codes" at the end of this document.

6.3 Structure of RTU Request Message (Data transmission from upper computer to this product)

■ See "6.5 Explanation about RTU Codes" for codes from (a) to (i).

6.3.1 Structure of Read Request Message

a)	Slave Address		1BH	
b)	Function Code		03H	
c)	Register Address	Upper	00H	First Register Address
		Lower	00H	
d)	No. of Registers	Upper	00H	2pcs. Fixed
		Lower	02H	
e)	CRC-16	Lower	C6H	
		Upper	31H	

6.3.2 Structure of Write Request Message

a)	Slave Address		03H	
b)	Function Code		10H	
c)	Register Address	Upper	00H	First Register Address
		Lower	02H	
d)	No. of Registers	Upper	00H	2pcs. Fixed
		Lower	02H	
f)	Nb. of Datas		04H	Nb. of Registers x 2
g)	Data to the first register (Lower word)	Upper	00H	③ Upon writing the data of ④ ①②③④H, write in the ① order as shown on the left. ② (① indicates 1 byte)
		Lower	6FH	
g)	Data to the first register + 1 (Upper word)	Upper	00H	
		Lower	00H	
e)	CRC-16	Lower	49H	
		Upper	D3H	

6.3.3 Structure of Save Request Message

a)	Slave Address		03H	
b)	Function Code		10H	
c)	Register Address	Upper	00H	First Register Address
		Lower	B0H	
d)	No. of Registers	Upper	00H	2pcs. Fixed
		Lower	02H	
f)	Nb. of Datas		04H	Nb. of Registers x 2
g)	Data to the first register (Lower word)	Upper	00H	Data of the saving of the setting is optional.
		Lower	00H	
g)	Data to the first register + 1 (Upper word)	Upper	00H	
		Lower	00H	
e)	CRC-16	Lower	F3H	
		Upper	63H	

6.4 Structure of RTU Response Message (Data transmission from this product to upper computer)

■ See "6.5 Explanation about RTU Codes" for codes from (a) to (h).

6.4.1 Response Message for Read Request Message

a)	Slave Address		1BH	
b)	Function Code		03H	
d)	Nb. of Datas		04H	No. of Registers x 2
g)	Data to the first register (Lower word)	Upper	03H	③
		Lower	09H	④
g)	Data to the first register + 1 (Upper word)	Upper	00H	①
		Lower	00H	②
e)	CRC-16	Lower	91H	
		Upper	B4H	

③ Upon writing the data of
④ ①②③④H, write in the
① order as shown on the left.
② (① indicates 1 byte)

6.4.2 Response Message for Write/Save Request Message

a)	Slave Address		03H	
b)	Function Code		10H	
c)	Register Address	Upper	00H	First Register Address
		Lower	02H	
d)	Nb. of Registers	Upper	00H	2pcs. Fixed
		Lower	02H	
e)	CRC-16	Lower	E1H	
		Upper	EAH	

6.4.3 Response Message for the Error

a)	Slave Address		1BH	
b)	Function Code		83H	← In case of error, function code of the request message + 80H will be stored.
h)	Error Code		02H	
e)	CRC-16	Lower	E1H	
		Upper	36H	

6.5 Explanation about RTU Codes

■ The following codes from (a) Slave Address, (b) Function Code, up to (h) Error Code will be expressed in 8-bit

binary:

a) Slave Address

It is an address of the device that will be communicated by the upper computer (this product).
The address in the response message from this product indicates the source of the response message.

b) Function Code

Enter the code 03H or 10H.

03H: If the data is to be read from this product

10H: If the data is to be written or saved into this product

c) Register Address

It specifies the position of data to be read or written with two bytes.

See "9. List of Identifiers (Codes)" for the address of each command.

Data will be retained in the holding register.

d) Number of Registers

It specifies the number of registers that write. Since the number of registers of this product is fixed to 2, set it to "0002H."

e) CRC-16

It is an error checking code for the detection of the possible error in the message. It sends CRC-16 (Cyclic Redundancy Code).

Generating polynomial of CRC-16 that is used in this product is $X^{16} + X^{15} + X^2 + 1$.

See "6.7 Sample Computation of CRC-16" for the computation method of CRC-16.

If it is to be attached at the end of the message as an error code, attach the lower byte of CRC before the upper byte.

f) Number of Bytes

It specifies the number of registers that read and write x 2. Since the number of registers of this product is 2 (fixed), set "04H."

g) Data Section

It specifies the data to be written into the register. Data is 4 bytes (fixed).

Data without decimal point will be written.

Example: In case of numerical data

Contents of Communication	HEX Data
Proportional Band (P) = 1. 0%	000000AH
PV = 200.0°C	00007DOH
SV = -10.00°C	FFFFC18H

Example: ASCII code will be written in case of the character data (means space)

Contents of Communication	HEX Data
Priority Screen 0-1 = <input type="checkbox"/> INP	20494E50H
Priority Screen 0-2 = <input type="checkbox"/> MV1	204D5631H
Priority Screen 0-3 = <input type="checkbox"/> <input type="checkbox"/> P1	20205031H

h) Type of ERR

If there is an error in the message that was sent by the upper computer, the error number will be included in the "response message" of this product for the reply.

Since error number "04" indicates the breakdown of measuring equipment (memory error, A/D conversion error, or AT error), it will be included in the "response message" whether or not there is an error in the "request message."

For multiple errors, the largest error number will be included.

Contents and classification of error are the following:

Error Number	Description of errors in the "request message" that was received by this product
01	Received an unsupported function code
02	Specified register address has no data
03	Numerical value data is out of the "setting range that is specified individually by the setting item"
04	Malfunction of measuring equipment (memory error or A/D conversion error, AT error)

6.6 Things to be Noted during RTU Communication

6.6.1 Timing of Transmission

Upon using RS-485, set enough response delay time to ensure the communication (sending/receiving) with the host computer.

See Figure of "6.1 Communication Procedures" and "5.8 Setting of Response Delay Time."

6.6.2 Request Interval

If the "request message" is to be sent continuously by the upper computer, wait for at least 2msecs. from the arrival of the "response message" from this product before sending the next request message.

6.6.3 Conditions for Response

This product will not return the "response message" if there is a time interval of more than 3.5 characters between data that consist the "request message" since it cannot identify these data as one whole "request message."

Therefore, although there is an error in the "request message," the "response message" with ERR will not be returned unless the above condition is met.

Therefore, the upper computer should resend the necessary "request message" if the "response message" is not returned within the reasonable time.

At a time interval of more than 3.5 characters, this product clears all characters that were received prior to the said interval.

6.6.4 Address Specification Error

This product will not respond to any "request message" that specifies the address that is other than the one that has been set to itself.

Therefore, if there is an error in the address section of the "request message," none of the slave stations will return the "response message."

Therefore, the upper computer should resend the necessary "request message" if the "response message" is not returned within the reasonable time.

6.6.5 Number of Digits of Data and Position of Decimal Point

See "6.5 Explanation about Codes (g) Numerical Data."

6.6.6 Operation After the Receiving of Save Request Message

This product starts the saving of data once it receives the save request message correctly from the upper computer.

Only the data that is different from the one stored in the EEPROM (changed data) shall be saved.

Time that is required to save the data (TW) is within 6 seconds.

The product sends a message when the saving of data is completed.

Some data may be lost if the product is turned OFF while the saving process is in progress. Do not turn the power of this product OFF for at least 6 seconds after the sending of save request message.

6.6.7 Upon Turning the Power ON

This product will not perform any communication for approximately 4 seconds after turning its power ON (no response). Set the delay from power ON to start communication.

6.6.8 Saving the Data Other than Save Request Message

This product saves the parameter into the EEPROM even without receiving the save request message in case of the following:

- 1) If the parameter is changed through key operation, it writes only changed parameters and other related parameters.
- 2) If the auto tuning is activated and ended normally, only the PID constant will be written.

6.6.9 Change of Setting Value (SV or SV2) by the Communication during Auto Tuning

If the value for control (SV or SV2) is changed via communication while the auto tuning is performed, the said value (SV or SV2) will not be changed until auto tuning ends.

6.7 Sample Computation of CRC-16

Below is the sample computation of CRC-16 using Visual Basic 6.0.

Declare the variable as shown below.

Since the unsigned variable cannot be used in VisualBasic6.0, a signed 16-bit integer variable is used for the data. Likewise, the computation result of CRC will be placed in the signed 32-bit integer variable.

```
Dim CRC As Long
Dim i, j, array_count As Integer

Dim c_next, c_carry As LongDim crc_array(64) As Integer
```

Next, data to be computed will be placed in `array_count` while the quantity of data will be placed in `array_count`.

After that, the computation result will be placed in CRC by executing the following program:

```
i = 0
CRC = 65535
For i = 0 To array_count
    c_next = array_count(i)
    CRC = (CRC Xor c_next) And 65535
    For j = 0 To 7
        c_carry = CRC And 1
        CRC = CRC \ 2
        If c_carry Then
            CRC = (CRC Xor &HA001) And 65535
        End If
    Next
Next
Next
```

If it is to be attached at the end of the message as an error code, attach the lower byte of CRC before the upper byte.

6.8 Structure of ASCII Request Message (Data transmission from upper computer to this product)

■ See "6.1 Explanation about ASCII Codes" for codes from (a) to (g).

6.8.1 Structure of Read Request Message

a)	Start Code		" : "	
b)	Slave Address		" 1 " , " B "	
c)	Function Code		" 0 " , " 3 "	
d)	Register Address	Upper	" 0 " , " 0 "	First Register Address
		Lower	" 0 " , " 0 "	
e)	Nb. of Registers	Upper	" 0 " , " 0 "	2pcs. Fixed
		Lower	" 0 " , " 2 "	
f)	LRC		" E " , " 0 "	
g)	End Code		CR,LF	

6.8.2 Structure of Write Request Message

a)	Start Code		" : "	
b)	Slave Address		" 0 " , " 3 "	
c)	Function Code		" 1 " , " 0 "	
d)	Register Address	Upper	" 0 " , " 0 "	First Register Address
		Lower	" 0 " , " 2 "	
e)	Nb. of Registers	Upper	" 0 " , " 0 "	2pcs. Fixed
		Lower	" 0 " , " 2 "	
h)	Nb. of Datas		" 0 " , " 4 "	Nb. of Registers x 2
i)	Data to the first register (Lower word)	Upper	" 0 " , " 0 "	③ Upon writing the data of ④ ①②③④H, write in the ① order as shown on the left. ② (① indicates 1 byte)
		Lower	" 6 " , " F "	
	Data to the first register + 1 (Upper word)	Upper	" 0 " , " 0 "	
		Lower	" 0 " , " 0 "	
f)	LRC		" 7 " , " 6 "	
g)	End Code		CR,LF	

6.8.3 Structure of Save Request Message

a)	Start Code		" : "	
b)	Slave Address		" 0 " , " 3 "	
c)	Function Code		" 1 " , " 0 "	
d)	Register Address	Upper	" 0 " , " 0 "	First Register Address
		Lower	" B " , " 0 "	
e)	Nb. of Registers	Upper	" 0 " , " 0 "	2pcs. Fixed
		Lower	" 0 " , " 2 "	
h)	Nb. of Datas		" 0 " , " 4 "	Nb. of Registers x 2
i)	Data to the first register (Lower word)	Upper	" 0 " , " 0 "	Data of the saving of the setting is optional.
		Lower	" 0 " , " 0 "	
	Data to the first register + 1 (Upper word)	Upper	" 0 " , " 0 "	
		Lower	" 0 " , " 0 "	
f)	LRC		" 3 " , " 7 "	
g)	End Code		CR,LF	

6.9 Structure of ASCII Response Message (Data transmission from this product to upper computer)

■ See "6.1 Explanation about ASCII Codes" for codes from (a) to (g).

6.9.1 Response Message for Read Request Message

a)	Start Code		":"	
b)	Slave Address		"1", "B"	
c)	Function Code		"0", "3"	
h)	Nb. of Datas		"0", "4"	No. of Registers x 2
i)	Data to the first register (Lower word)	Upper	"0", "3"	③
		Lower	"0", "9"	④
	Data to the first register + 1 (Upper word)	Upper	"0", "0"	①
		Lower	"0", "0"	②
f)	LRC		"D", "2"	
e)	End Code		CR,LF	

③ Upon writing the data of
④ ①②③④H, write in the
① order as shown on the left.
② (① indicates 1 byte)

6.9.2 Response Message for Write/Save Request Message

a)	Start Code		":"	
b)	Slave Address		"0", "3"	
c)	Function Code		"1", "0"	
d)	Register Address	Upper	"0", "0"	First Register Address
		Lower	"0", "2"	
e)	Nb. of Registers	Upper	"0", "0"	2pcs. Fixed
		Lower	"0", "2"	
f)	LRC		"E", "9"	
g)	End Code		CR,LF	

6.9.3 Response Message for the Error

a)	Start Code		":"	
b)	Slave Address		"1", "B"	
h)	Function Code		"8", "3"	← In case of error, function code of the request message + 80H will be stored.
j)	Error Code		"0", "2"	
f)	LRC		"6", "0"	
e)	End Code		CR,LF	

6.10 Explanation about ASCII Codes

■ The following codes from (a) Start Code, (b) Slave Address, up to (j) Error Type will be expressed in ASCII code:

■ See "10. List of ASCII Codes" for the details about ASCII codes.

■ To convert into ASCII code, see the message structure in 6.8 and 6.9.

a) Start Code

It is a code that is necessary for the receiving side to detect the start of the message. It shall be attached to the start of the character string to be sent.

b) Slave Address

It is an address of the device that will be communicated by the upper computer (this product). The address in the response message from this product indicates the source of the response message.

c) Function Code

Enter the code 03H or 10H.

03H: If the data is to be read from this product

10H: If the data is to be written or saved into this product

d) Number of Registers

It specifies the number of registers that write. Since the number of registers of this product is fixed to 2, set it to "0002H."

e) Register Address

It specifies the position of data to be read or written with two bytes.

See "10. List of Identifiers (Codes)" for the address of each command.

f) LRC

It is an error checking code for the detection of the possible error in the message. It sends LRC. LRC that is used in this product is a value where all data in the message, except for start code and end code, are summed up without performing a carryover and treat the sum total as the complement of 2.

Any portion that is expressed as "1" and "B" shall be considered as "1BH."

See "6.12 Sample Computation of LRC" for the computation method of LRC.

If 12H was computed as an error code, attach "1" and "2" at the end of the message.

g) End Code

It is a code that is necessary for the receiving side to detect the end of the message. CR(0DH) and LF(0AH) shall be attached at the end of the character string to be sent.

h) Number of Bytes

It specifies the number of registers that read and write x 2. Since the number of registers of this product is 2 (fixed), set "04H."

i) Data Section

It specifies the data to be written into the register. Data is 4 bytes (fixed).
Data without decimal point will be written.

Example: In case of numerical data

Contents of Communication	HEX Data
Proportional Band (P) = 1.0%	000000AH
PV = 200.0□	000007D0H
SV = -10.00□	FFFFC18H

Example: ASCII code will be written in case of the character data (□ means space)

Contents of Communication	HEX Data
Priority Screen 0-1 = □INP	20494E50H
Priority Screen 0-2 = □MV1	204D5631H
Priority Screen 0-3 = □□P1	20205031H

j) Type of ERR

If there is an error in the message that was sent by the upper computer, the error number will be included in the "response message" of this product for the reply.

Since error number "04" indicates the breakdown of measuring equipment (memory error, A/D conversion error, or AT error), it will be included in the "response message" whether or not there is an error in the "request message."

For multiple errors, the largest error number will be included.

Contents and classification of error are the following:

Error Number	Description of errors in the "request message" that was received by this product
01	Received an unsupported function code
02	Specified register address has no data
03	Numerical value data is out of the "setting range that is specified individually by the setting item"
04	Malfunction of measuring equipment (Memory error or A/D conversion error, AT error)

6.11 Things to Be Noted during ASCII Communication

6.11.1 Timing of Transmission

Upon using RS-485, set enough response delay time to ensure the communication (sending/receiving) with the host computer.

See Figure of "6.1 Communication Procedures" and "5.8 Setting of Response Delay Time."

6.11.2 Request Interval

If the "request message" is to be sent continuously by the upper computer, wait for at least 2msecs. from the arrival of the "response message" from this product before sending the next request message.

6.11.3 Conditions for Response

This product will not return the "response message" if start code and end code are not included in the "request message."

Therefore, although there is an error in the "request message," the "response message" with NAK and error code will not be returned unless the above condition is met.

Therefore, the upper computer should resend the necessary "request message" if the "response message" is not returned within the reasonable time.

Once the start code is received, this product clears all codes that were received prior to the said start code.

6.11.4 Address Specification Error

This product will not respond to any "request message" that specifies the address that is other than the one that has been set to itself.

Therefore, if there is an error in the address section of the "request message," none of the slave stations will return the "response message."

Therefore, the upper computer should resend the necessary "request message" if the "response message" is not returned within the reasonable time.

6.11.5 Number of Digits of Data and Position of Decimal Point

See "6.10 Explanation about Codes (h) Numerical Data."

6.11.6 Operation After the Receiving of Save Request Message

This product starts the saving of data once it receives the save request message correctly from the upper computer.

Only the data that is different from the one stored in the EEPROM (changed data) shall be saved.

Time that is required to save the data (TW) is within 6 seconds.

The product sends a message when the saving of data is completed.

Some data may be lost if the product is turned OFF while the saving process is in progress. Do not turn the power of this product OFF for at least 6 seconds after the sending of save request message.

6.11.7 Upon Turning the Power ON

This product will not perform any communication for approximately 4 seconds after turning its power ON (no response). Set the delay from power ON to start communication.

6.11.8 Saving the Data Other than Save Request Message

This product saves the parameter into the EEPROM even without receiving the save request message in case of the following:

- 1) If the parameter is changed through key operation, it writes only changed parameters and other related parameters.
- 2) If the auto tuning is activated and ended normally, only the PID constant will be written.

6.11.9 Change of Setting Value (SV or SV2) by the Communication during Auto Tuning

If the value for control (SV or SV2) is changed via communication while the auto tuning is performed, the said value (SV or SV2) will not be changed until auto tuning ends.

6.12 Sample Computation of LRC

Below is the sample computation of LRC using VisualBasic6.0.

Declare the variable as shown below.

Since the unsigned variable cannot be used in VisualBasic6.0, a signed 16-bit integer variable is used for the data. Likewise, the computation result of LRC will be placed in the signed 16-bit integer variable.

```
Dim LRC As Integer
```

```
Dim i, array_count As Integer
```

```
Dim lrc_array(128) As Integer
```

Next, data to be computed will be placed in lrc_array() while the quantity of data will be placed in array_count.

After that, the computation result will be placed in LRC by executing the following program:

```
For i = 0 To array_count
```

```
    LRC = (LRC + lrc_array(i)) And &HFF
```

```
Next
```

```
LRC = ((Not LRC) + 1) And &HFF
```

For example, if 12H was computed as an error code, attach "1" and "2" at the end of the message.

7. Specifications

7.1 Type of Communication Standard: EIA Standard Based on RS-485

7.2 Communication Specifications

7.2.1 Communication Method

- : Network.....Multidrop System (1 to 31 stations)
- : Direction of Information.....Half-Duplex
- : Synchronization System.....Start-Stop Synchronization
- : Transmission Code.....ASCII 7-bit Code (except for BCC data)
(For 8-bit code, top bit = 0)

7.2.2 Interface System

- : Signal Wire.....Two wires for sending and receiving
- : Communication Speed.....1200, 2400, 4800, 9600, 19200BPS
Select and set the above.
- : Communication Distance.....Up to 500m
However, the distance may vary depending on the surrounding environment, such as cable.

7.2.3 Character

- 1) TOHO Communication Protocol
 - : Start Bit Length.....1 bit fixed
 - : Stop Bit Length: Select and set from 1 bit and 2 bits
 - : Data Length: Select and set from 7 bits and 8 bits
 - : Parity.....Select and set from none, odd, and even
 - : BCC Checking.....Select and set from Yes (with) and No (without)
 - : Communication Address.....1-99
- 2) MODBUS (RTU) Communication Protocol
 - : Start Bit Length.....1 bit fixed
 - : Stop Bit Length: Select and set from 1 bit and 2 bits (With parity: 1 bit fixed)
 - : Data Length.....8 bits fixed
 - : Parity.....Select and set from none, odd, and even
 - : CRC-16 Check...ON fixed
 - : Communication Address.....1-247
- 3) MODBUS (ASCII) Communication Protocol
 - : Start Bit Length.....1 bit fixed
 - : Stop Bit Length: Select and set from 1 bit and 2 bits (With parity: 1 bit fixed)
 - : Data Length.....7 bits fixed
 - : Parity.....Select and set from none, odd, and even
 - : LRC Check..... ON fixed
 - : Communication Address.....1-247
- 4) MODBUS (RTU/ASCII) Communication Function Code
 - : 03H (Read the content of the holding register)
 - : 10H (Write the content of multiple holding registers)

8. Wiring

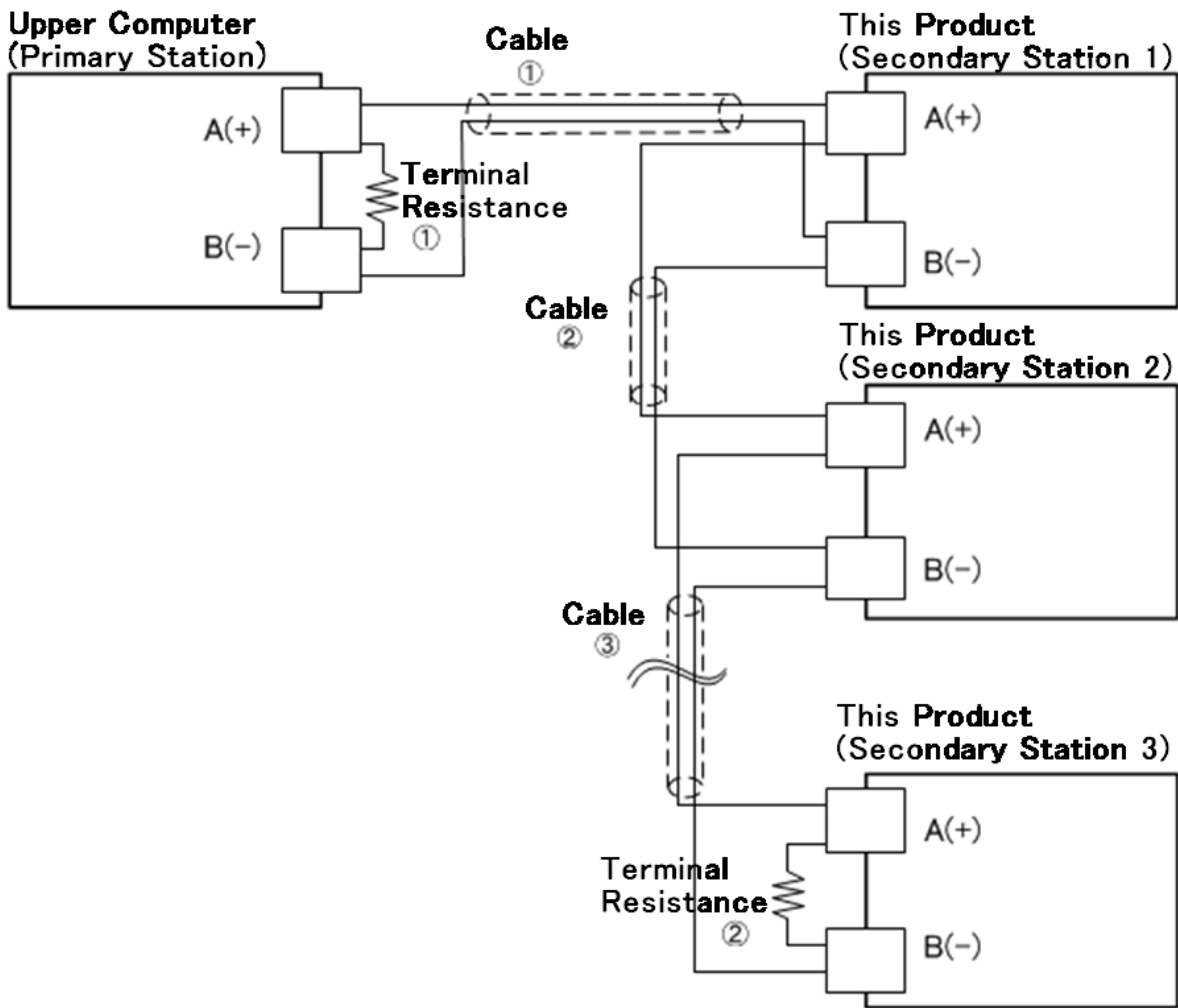

- The figure below shows the example of the case where secondary stations 1-3 (3 stations) will be connected to the primary station.
 - ◇ For cables ①-③, use the cable with the same characteristic impedance.
 - Connect secondary stations 1-3 as slave, as shown in the figure.
 - Use the cable with the same characteristic impedance for the connection between secondary stations as well.
 - ◇ Attach the terminator to both the primary station ① and the farthest secondary station ② (secondary station 3).
 - ◇ Choose the terminator of which $[\text{Characteristic impedance of cables ①-③}] = [\text{Resistance of ①}] = [\text{Resistance of ②}]$.
 - Also, use the cable with characteristic impedance where $[\text{Resistance of ①}] // [\text{Resistance of ②}]$ (parallel combined resistance) is 75Ω or higher.

9. List of Identifiers (Codes)

■ See the User's Manual of this product for setting range, selection items, initial value, and other related information.

- a) Identifier: Symbol that expresses the item. Place this symbol in the identifier within the message. Furthermore, "□" inside the frame indicates SP (ASCII code: 20H).
- b) Character: Character to be displayed on the display of the product
- c) Name: Name of the item
- d) R/W: Describe whether read or write is possible. Or describe if both read and write are possible.
- e) Explanation:

Caution: "NAK2" will be responded for the R/W to the character that does not satisfy the display condition.

Example: If EV2 option is not selected, R/W to the character of EV2 will be "NAK2."

Identifier	Relative Address	Absolute Address	Character	Name	R/W	Description
PV1	0000h	40001		Measuring Value (PV)	R	To be used as a monitor of measuring value (PV) If Over Scale: HHHHH
SV1	0002h	40003		Set Value (SV)	R/W	R/W of Set Value (SV)
PR1	0004h	40005	P r i 1	Priority Screen Function Setting 1	R/W	R/W of Priority Screen Function Setting 1
PR2	0006h	40007	P r i 2	Priority Screen Function Setting 2	R/W	R/W of Priority Screen Function Setting 2
PR3	0008h	40009	P r i 3	Priority Screen Function Setting 3	R/W	R/W of Priority Screen Function Setting 3
PR4	000Ah	40011	P r i 4	Priority Screen Function Setting 4	R/W	R/W of Priority Screen Function Setting 4
PR5	000Ch	40013	P r i 5	Priority Screen Function Setting 5	R/W	R/W of Priority Screen Function Setting 5
PR6	000Eh	40015	P r i 6	Priority Screen Function Setting 6	R/W	R/W of Priority Screen Function Setting 6
PR7	0010h	40017	P r i 7	Priority Screen Function Setting 7	R/W	R/W of Priority Screen Function Setting 7
PR8	0012h	40019	P r i 8	Priority Screen Function Setting 8	R/W	R/W of Priority Screen Function Setting 8
PR9	0014h	40021	P r i 9	Priority Screen Function Setting 9	R/W	R/W of Priority Screen Function Setting 9
INP	0016h	40023	_ I n P	Setting of Input Type	R/W	R/W of the Setting of Input Type
PVG	0018h	40025	_ P v G	Setting of Gain of PV	R/W	R/W of the Setting of Gain of PV
PVS	001Ah	40027	_ P v S	Setting of Zero Point of	R/W	R/W of the Setting of Zero Point of PV
PDF	001Ch	40029	_ P d F	Setting of Input Filter	R/W	R/W of the Setting of Input Filter
□DP	001Eh	40031	_ d P	Setting of Decimal Point	R/W	R/W of the Setting of Decimal Point Without Decimal Point: 00000 With Decimal Point: 00001
□FU	0020h	40033	_ F U	Function Key Function Settings	R/W	R/W of the Setting of Function Key Function
LOC	0022h	40035	_ L o C	Key Lock Settings	R/W	R/W of the Key Lock Settings
SLH	0024h	40037	_ S L H	Setting of the Maximum	R/W	R/W of the Setting of the Maximum Limit
S L L	0026h	40039	_ S L L	Setting of the Minimum	R/W	R/W of the Setting of the Minimum Limit
□MD	0028h	40041	_ M d	Setting of Control Mode	R/W	R/W of the Setting of Control Mode Execution of Control: 00000 Manual Control: 00001 Stop the Control: 00002 Auto Tuning Is in Progress: 00003

Identifier	Relative Address	Absolute Address	Character	Name	R/W	Description
CNT	002Ah	40043	_CnE	Setting of Control Type	R/W	R/W of the Setting of Control Type
DIR	002Ch	40045	_dI r	Switching of Direct	R/W	R/W of the Switching of Direct Ac-
MV1	002Eh	40047	_Mv1	Manipulated Variable of	R/W	R/W of the Manipulated Variable of
TUN	0030h	40049	_tUn	Setting of Tuning Type	R/W	R/W of the Setting of Tuning Type
ATG	0032h	40051	_AtG	9. AT Coefficient	R/W	R/W of AT Coefficient
ATC	0034h	40053	_AtC	AT Sensitivity	R/W	R/W of AT Sensitivity
<input type="checkbox"/> P1	0036h	40055	_P1	Setting of the Propor-	R/W	R/W of the Setting of the Proportional
<input type="checkbox"/> I1	0038h	40057	_I1	Setting of Reset Time	R/W	R/W of the Setting of Reset Time
<input type="checkbox"/> D 1	003Ah	40059	_d	Setting of Derivative	R/W	R/W of the Setting of Derivative Time
<input type="checkbox"/> T1	003Ch	40061	_t1	Setting of the Propor-	R/W	R/W of the Setting of the Proportional
ARW	003Eh	40063	_ARW	Anti-Reset Windup	R/W	R/W of Anti-Reset Windup
MH1	0040h	40065	_MH1	Maximum Limit of MV Limiter	R/W	R/W of the Maximum Limit of MV Limiter
ML1	0042h	40067	_ML1	Minimum Limit of MV Limiter	R/W	R/W of the Minimum Limit of MV Limiter
<input type="checkbox"/> C1	0044h	40069	_C1	Setting of the Control	R/W	R/W of the Setting of the Control
CP1	0046h	40071	_CP1	Setting of the OFF Point of Output 1	R/W	R/W of the Setting of the OFF Point of Output 1
MV2	0048h	40073	_Mv2	Manipulated Variable of	R/W	R/W of the Manipulated Variable of
<input type="checkbox"/> P2	004Ah	40075	_P2	Setting of the Propor-	R/W	R/W of the Setting of the Proportional
<input type="checkbox"/> T2	004Ch	40077	_t2	Setting of the Propor-	R/W	R/W of the Setting of the Proportional
MH2	004Eh	40079	_MH2	Maximum Limit of MV Limiter	R/W	R/W of the Maximum Limit of MV Limiter
ML2	0050h	40081	_ML2	Minimum Limit of MV Limiter	R/W	R/W of the Minimum Limit of MV Limiter
<input type="checkbox"/> C2	0052h	40083	_C2	Setting of the Control	R/W	R/W of the Setting of the Control
CP2	0054h	40085	_CP2	OFF Point of Output 2 Settings	R/W	R/W of the OFF Point of Output 2
PBB	0056h	40087	_Pbb	Manual Reset	R/W	R/W of the Manual Reset
<input type="checkbox"/> DB	0058h	40089	_db	Setting of Dead Band	R/W	R/W of the Setting of Dead Band
RP1	005Ah	40091	_rP1	Setting of SV Ramp Time	R/W	R/W of the Setting of SV Ramp Time
RP2	005Ch	40093	_rP2	Setting of SV2 Ramp Time	R/W	R/W of the Setting of SV2 Ramp Time
EIF	005Eh	40095	_E IF	PV Event Output 1 Function	R/W	R/W of the PV Event Output 1 Function
EIH	0060h	40097	_E IH	Maximum Limit of Event Output 1	R/W	R/W of the Maximum Limit of Event Output 1
EIL	0062h	40099	_E IL	Minimum Limit of Event Output 1	R/W	R/W of the Minimum Limit of Event Output 1
EIC	0064h	40101	_E IC	Event Output 1 Sensitivity	R/W	R/W of the Setting of Event Output 1 Sensitivity
EIT	0066h	40103	_E IE	Event Output 1 Delay Timer Setting	R/W	R/W of the Setting of Event Output 1 Delay Timer
E 1 B	0068h	40105	_E Ib	Special Event Output 1 Function	R/W	R/W of the Setting of Special Event Output 1 Function
EIP	006Ah	40107	_E IP	Event Output 1 Polarity Settings	R/W	R/W of the Setting of Event Output 1 Polarity
CM1	006Ch	40109	_CE	CT Input Monitor	R	R of CT Input Monitor
CT1	006Eh	40111	_CE I	Event Output 1 Current Abnormality	R/W	R/W of the Setting of Event Output 1 Current Abnormality

Identifier	Relative Address	Absolute Address	Character	Name	R/W	Description
E2F	0070h	40113	<u>E2F</u>	PV Event Output 2 Function	R/W	R/W of the Setting of PV Event Output 2 Function
E2H	0072h	40115	<u>E2H</u>	Maximum Limit of Event Output 2	R/W	R/W of the Maximum Limit of Event Output 2
E2L	0074h	40117	<u>E2L</u>	Event Output 2 Minimum	R/W	R/W of the Minimum Limit of Event Output
E2C	0076h	40119	<u>E2C</u>	Event Output 2 Sensitivity	R/W	R/W of the Setting of Event Output 2 Sensitivity
E2T	0078h	40121	<u>E2T</u>	Event Output 2 Delay Timer Setting	R/W	R/W of the Setting of Event Output 2 Delay Timer
E2B	007Ah	40123	<u>E2B</u>	Special Event Output 2 Function	R/W	R/W of the Setting of Special Event Output 2 Function
E2P	007Ch	40125	<u>E2P</u>	Event Output 2 Polarity	R/W	R/W of the Setting of Event Output 2
CM2	007Eh	40127	<u>CE</u>	CT Input Monitor	R	R of CT Input Monitor
CT2	0080h	40129	<u>CE2</u>	Event Output 2 Current Abnormality	R/W	R/W of the Setting of Event Output 2 Current Abnormality
DIF	0082h	40131	<u>dIF</u>	Setting of DI Input	R/W	R/W of the Setting of DI Input Function
DIP	0084h	40133	<u>dIP</u>	Setting of DI Polarity	R/W	R/W of the Setting of DI Polarity
SV2	0086h	40135	<u>Su2</u>	Control Setting 2	R/W	R/W of the Setting of Control Setting
PRT	0088h	40137	<u>Prt</u>	Setting of Communication Protocol	R/W	R/W of the Setting of Communication Protocol Dedicated Protocol: 00000 MODBUS (RTU): 00001
COM	008Ah	40139	<u>Con</u>	Setting of Communication Parameters	R/W	R/W of the Setting of Communication Parameters
BPS	008Ch	40141	<u>bPS</u>	Setting of Communication Speed	R/W	R/W of the Setting of Communication Speed
ADR	008Eh	40143	<u>Adr</u>	Communication Address	R/W	R/W of Communication Address Setting
AWT	0090h	40145	<u>AWt</u>	Setting of Response	R/W	R/W of the Setting of Response Delay
MOD	0092h	40147	<u>Mod</u>	Switching of Communication Mode Settings	R/W	R/W of the Setting of the Switching of Communication Mode R0: 00000
TMO	0094h	40149	<u>TMo</u>	Setting of Timer Output	R/W	R/W of the Setting of Timer Output
TMF	0096h	40151	<u>TMF</u>	Setting of Timer Function	R/W	R/W of the Setting of Timer Function
H/M	0098h	40153	<u>HrM</u>	Switching of Timer Unit	R/W	R/W of the Switching of Timer Unit
TSV	009Ah	40155	<u>TSu</u>	Timer SV Start Permission	R/W	R/W of the Setting of Timer SV Start Permission Range
TIM	009Ch	40157	<u>TM</u>	Timer Time Setting	R/W	R/W of Timer Time Setting
TIA	009Eh	40159	<u>TMt</u>	Timer Remaining Time	R	R of Timer Remaining Time Monitor
TRF	00A0h	40161	<u>TrF</u>	Setting of Transmission	R/W	R/W of the Setting of Transmission
TRP	00A2h	40163	<u>TrP</u>	Direct Action/Reverse Action of Transmission	R/W	R/W of the Setting of Direct Action/Reverse Action of Transmission
TRH	00A4h	40165	<u>TrH</u>	Setting of Transmission	R/W	R/W of the Setting of Transmission Output
TRL	00A6h	40167	<u>TrL</u>	Setting of Transmission	R/W	R/W of the Setting of Transmission Output
TST	00A8h	40169		Timer Start /Stop	R/W	W of Timer Start/Stop Start: 00001 Stop: 00000
OM1	00AAh	40171		Output Status Monitor	R	R of Output Monitor ①②③④⑤ ⑤ : OUT1 (1: ON 0: OFF) ④ : OUT2 (1: ON 0: OFF) ③ : EV1 (1: ON 0: OFF) ② : EV2 (1: ON 0: OFF)
EM1	00ACh	40173		DI Status Monitor	R	R of DI Monitor ON: 00001 OFF:00000

Identifier	Relative Address	Absolute Address	Character	Name	R/W	Description
<input type="checkbox"/> AT	00AEh	40175		AT Start/Cancel	R/W	R/W of AT Start/Cancel Start: 00001 Cancel: 00000
STR	00B0h	40177		Save Data	W	Save Data

Identifier that will be used only at the blind setting

Identifier	Relative Address	Absolute Address	Character	Name	L/B	Description
000			SEED	SET0	L/B	Blind: 00000 Do not blind: 00001
001			SEED1	SET1	L/B	Blind: 00000 Do not blind: 00001
002			SEED2	SET2	L/B	Blind: 00000 Do not blind: 00001
003			SEED3	SET3	L/B	Blind: 00000 Do not blind: 00001
004			SEED4	SET4	L/B	Blind: 00000 Do not blind: 00001
005			SEED5	SET5	L/B	Blind: 00000 Do not blind: 00001
006			SEED6	SET6	L/B	Blind: 00000 Do not blind: 00001
007			SEED7	SET7	L/B	Blind: 00000 Do not blind: 00001
008			SEED8	SET8	L/B	Blind: 00000 Do not blind: 00001

10. List of ASCII Codes

Up- per Lower	00h	10h	20h	30h	40h	50h	60h	70h
00h	NUL	DLE	Space	0	@	P	`	p
01h	SOH	DC1	!	1	A	Q	a	q
02h	STX	DC2	"	2	B	R	b	r
03h	ETX	DC3	#	3	C	S	c	s
04h	EOT	DC4	\$	4	D	T	d	t
05h	ENQ	NAK	%	5	E	U	e	u
06h	ACK	SYN	&	6	F	V	f	v
07h	BEL	ETB	'	7	G	W	g	w
08h	BS	CAN	(8	H	X	h	x
09h	HT	EM)	9	I	Y	i	y
0Ah	LF	SUB	*	:	J	Z	j	z
0Bh	VT	ESC	+	;	K	[k	{
0Ch	FF	FS	,	<	L	¥	l	
0Dh	CR	GS	-	=	M]	m	}
0Eh	SO	RS	.	>	N	^	n	~
0Fh	SI	US	/	?	O	_	o	DEL

※How to Use the ASCII Code Table:
 (ASCII Code) = (Upper) + (Lower)

Example 1: If "A": (41h) = (40h) + (01h)

Example 2: If "m": (6Dh) = (60h) + (0Dh)

TOHO ELECTRONICS INC.

Main Office: 2-4-3 Nishi-Hashimoto, Midori-Ku, Sagami-hara-Shi, Kanagawa-Ken 252-0131 Japan
TEL: (042) 700-2100 (Representative Line)
FAX: (042) 700-2112

Tokyo Office: 401 Palace Yoyogi Uehara, 3-1-8 Nishihara, Shibuya-Ku, Tokyo 151-0066 Japan
TEL: (03) 5452-4010 (Representative Line)
FAX: (03) 5452-4017

Osaka Office: 7F East Hall, Yachiyo Bldg., 2-1-21 Tenjinbashi, Kita-Ku, Osaka-Shi, Osaka 530-0041 Japan
TEL: (06) 6353-9205 (Representative Line)
FAX: (06) 6353-9273

Kumamoto Office: 2-10-23 Higashino, Higashi-Ku, Kumamoto-Shi, Kumamoto-Ken 861-2106 Japan
TEL: (096) 214-6507 (Representative Line)
FAX: (096) 214-6510

4D-0148